

## ELECTRIC SCISSOR LIFTS

# 0812N (2746N)/1012N(3346N)/ 1212N(4046N)

Compliance with CE/ANSI/EAC standards

### PRODUCT HIGHLIGHTS

#### Compatible Components

- Components used on Neo series scissor lift are common and compatible with last generation's scissor lift, decreasing total operating cost for rental companies and end users

#### Safe and Reliable

- Extensively tested and verified Sinoboomb control system, function-integrated ECU with wide screen for easy and highly efficient operation. Reliable PCU features high degree of protection, which is collision and crash resistance
- Automobile-grade electrophoretic coating process is applied on the machine, coating is deposited on the surface of the metal to prevent corrosion, and aging of paint while providing a consistent and durable paint finish

#### Easy Maintenance

- AGM maintenance-free batteries come as standard, long runtime and require less maintenance
- Swing-out trays provide easy access to components, self-diagnosis system and markers on each cable & tube that are benefit to easy and quick maintenance
- Unique bumper rails protect decals and paint well, keeping machine looking like new

#### Best Productivity

- Front wheel drive and steering provides small turning radius and anti-slip when drive indoors
- Machine can be used both indoor and outdoor, greatly improve work efficiency at work site
- Available options would help get jobs done easily and efficiently



#### Standard Features

2WD×2WS	AGM maintenance-free battery	Indoor & outdoor use
Non-marking tires	Proportional control	Fault diagnosis system
Emergency stop	Electrophoretic painting	Emergency lowering system
Flashing beacon	Forklift pockets and lifting points	Tilt protection system
Foldable guardrail	Automatic pothole protection	Overload sensing system
Drivable at full height	Bumper rails	Manual storage box
Horn & buzzer	Telematics-ready connector	Auto braking system

#### Options & Accessories

Footswitch	Overhead anti-collision device	Lithium battery
RCBO	AC power to platform	

**SINOBOOM™**

**PARTNERS IN ACCESS™**

[SINOBOOM.COM](http://SINOBOOM.COM) | [SALES@SINOBOOM.COM](mailto:SALES@SINOBOOM.COM)

NO.128 EAST JINZHOU AV., NINGXIANG HI-TECH INDUSTRY PARK, CHANGSHA, HUNAN, CHINA, 410600

# ELECTRIC SCISSOR LIFTS

## 0812N (2746N)

Compliance with CE/ANSI/EAC standards

Model	0812N (2746N)
<b>Dimensions</b>	
Max Working Height (Indoor/Outdoor)	10.1 m (33'2")
A Max Platform Height (Indoor/Outdoor)	8.1 m (26' 7")
B Platform Extension	0.9 m (3')
C Length-Stowed	2.39 m (7'10.1")
D Width-Stowed	1.18 m (3'10.5")
E Height-stowed (Rails Folded)	1.73 m (5'8.1")
E Height-stowed (Rails Unfolded)	2.36 m (7'9")
F Wheelbase	1.85 m (6'0.8")
Ground Clearance (Pothole Guard Stowed)	0.088 m (3.5")
Ground Clearance (Pothole Guard Deployed)	0.025 m (0.98")
Platform Size (L×W×H)	2.25 m×1.15 m×1.1 m (7'4.6"×3'9"×3'7")
<b>Performance</b>	
Platform Capacity	450 kg (992 lbs)
Extension Platform Capacity	120 kg (265 lbs)
Max Platform Occupants (Indoor/Outdoor)	2 Persons
Drive Speed (Stowed)	3.2 km/h (2 mph)
Drive Speed (Raised)	0.5 km/h (0.31 mph)
Lift Time (Unloaded)	33 s~38 s
Lower Time (Unloaded)	35 s~40 s
Gradeability	25%
Max Allowable Inclination (front-to-back/side-to-side)	3°/1.5°
Turning Radius (Inside/Outside)	0.18 m/2.35 m (7.1"/7'8.5")
Tire Spec/Type	380×125 mm/solid (15×5")
<b>Power</b>	
Drive × Steer	2 WD×2 WS
Power Source (V/kW)	24V DC, 3.3 kW
Hydraulic Tank Capacity	15 L (3.3 gal (UK) / 4.0 gal (US))
Hydraulic System Capacity	21 L (4.6 gal (UK) / 5.5 gal (US))
Batteries	24 V, 220 Ah (AGM maintenance-free battery) 25.6 V, 200 Ah (Lithium battery)
Charger (Input/Output)	100~240 V AC/30 A
<b>Weight</b>	
Weight	2,500 kg (5,512 lbs)
Standards Compliance	CE/ANSI/EAC

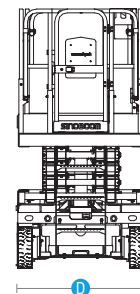
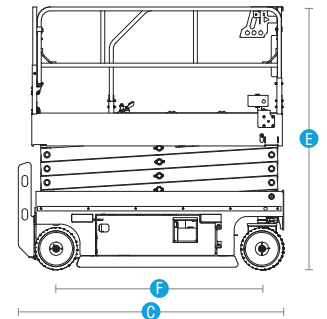
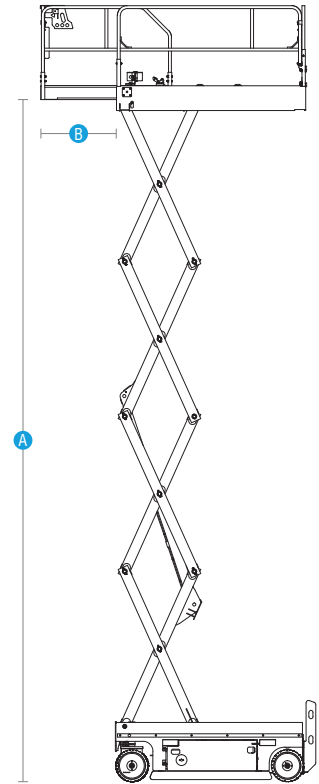

# ELECTRIC SCISSOR LIFTS 1012N (3346N)

Compliance with CE/ANSI/EAC standards

Model	1012N (3346N)
<b>Dimensions</b>	
Max Working Height (Indoor/Outdoor)	12 m (39'4.5")
A Max Platform Height (Indoor/Outdoor)	10 m (32'10")
B Platform Extension	0.9 m (3')
C Length-Stowed	2.39 m (7'10.1")
D Width-Stowed	1.18 m (3'10.5")
E Height-stowed (Rails Folded)	1.86 m (6'1")
E Height-stowed (Rails Unfolded)	2.49 m (8'2")
F Wheelbase	1.85 m (6'0.8")
Ground Clearance (Pothole Guard Stowed)	0.088 m (3.5")
Ground Clearance (Pothole Guard Deployed)	0.025 m (0.98")
Platform Size (L×W×H)	2.25 m×1.15 m×1.1 m (7'4.6"×3'9"×3'7")
<b>Performance</b>	
Platform Capacity	320 kg (705 lbs)
Extension Platform Capacity	120 kg (265 lbs)
Max Platform Occupants (Indoor/Outdoor)	2 Persons / 1 Person
Drive Speed (Stowed)	3.2 km/h (2 mph)
Drive Speed (Raised)	0.5 km/h (0.31 mph)
Lift Time (Unloaded)	53 s~58 s
Lower Time (Unloaded)	40 s~45 s
Gradeability	25%
Max Allowable Inclination (front-to-back/side-to-side)	3° / 1.5°
Turning Radius (Inside/Outside)	0.18 m/2.35 m (7.1"/7'8.5")
Tire Spec/Type	380×125 mm/solid (15×5")
<b>Power</b>	
Drive × Steer	2 WD×2 WS
Power Source (V/kW)	24V DC, 3.3 kW
Hydraulic Tank Capacity	15 L (3.3 gal (UK) / 4.0 gal (US))
Hydraulic System Capacity	23 L (5.1 gal (UK) / 6.1 gal (US))
Batteries	24 V, 220 Ah (AGM maintenance-free battery) 25.6 V, 200 Ah (Lithium battery)
Charger (Input/Output)	100~240 V AC/30 A
<b>Weight</b>	
Weight	2,610 kg (5,754 lbs)
Standards Compliance	CE/ANSI/EAC

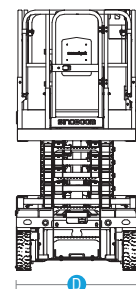
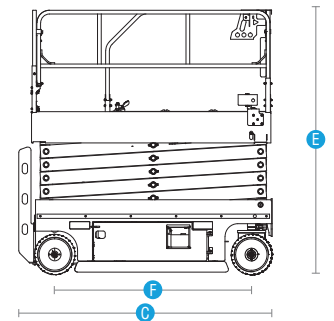
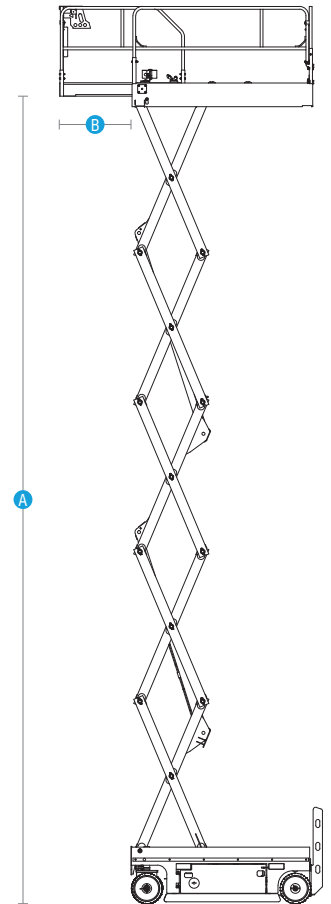

# ELECTRIC SCISSOR LIFTS 1212N(4046N)

Compliance with CE/ANSI/EAC standards

Model	1212N (4046N)
<b>Dimensions</b>	
Max Working Height (Indoor/Outdoor)	13.9 m (45'7") / 11 m (36'1")
A Max Platform Height (Indoor/Outdoor)	11.9 m (45'7") / 9 m (29'6")
B Platform Extension	0.9 m (3')
C Length-Stowed	2.39 m (7'10.1")
D Width-Stowed	1.18 m (3'10.5")
E Height-stowed (Rails Folded)	1.98 m (6'6")
E Height-stowed (Rails Unfolded)	2.62 m (8'7.1")
F Wheelbase	1.85 m (6'0.8")
Ground Clearance (Pothole Guard Stowed)	0.088 m (3.5")
Ground Clearance (Pothole Guard Deployed)	0.025 m (0.98")
Platform Size (L×W×H)	2.25 m×1.15 m×1.1 m (7'4.6"×3'9"×3'7")
<b>Performance</b>	
Platform Capacity	320 kg (705 lbs)
Extension Platform Capacity	120 kg (265 lbs)
Max Platform Occupants (Indoor/Outdoor)	2 Persons / 1 Person
Drive Speed (Stowed)	3.2 km/h (2 mph)
Drive Speed (Raised)	0.5 km/h (0.31 mph)
Lift Time (Unloaded)	63 s~68 s
Lower Time (Unloaded)	44 s~49 s
Gradeability	25%
Max Allowable Inclination (front-to-back/side-to-side)	3° / 1.5°
Turning Radius (Inside/Outside)	0.18 m / 2.35 m (7.1"/7'8.5")
Tire Spec/Type	380×125 mm / solid (15×5")
<b>Power</b>	
Drive × Steer	2 WD×2 WS
Power Source (V/kW)	24V DC, 4.5 kW
Hydraulic Tank Capacity	15 L (3.3 gal (UK) / 4.0 gal (US))
Hydraulic System Capacity	24.5 L (5.4 gal(UK) / 6.5 gal (US))
Batteries	24 V, 280 Ah (AGM maintenance-free battery) 25.6 V, 200 Ah (Lithium battery)
Charger (Input/Output)	100~240 V AC/30 A
<b>Weight</b>	
Weight	2,880 kg (6,349 lbs)
Standards Compliance	CE/ANSI/EAC

